

**UPHOLSTERED PANEL FOR
SEAT AND/OR BACK**

24", 30" & 48" BANQUETTE HARDWARE LIST

- (48) #8x1" Round Washer Head Screws
- (2) 5/16-18 x 1" Bolt + 5/16-18 Nut (Hex Flange)
- (1) 3/4" Spacer Board
- (2) 9-1/2"W Back Boards
- (2) 7-1/2"W Seat Boards
- (2) Seat Brackets

TOOLS NEEDED

- Tape Measure
- Drill
- #2 Square Head Bit
- 2- 1/2" Open End Wrench

60" & 72" BANQUETTE HARDWARE LIST

- (72) #8x1" Round Washer Head Screws
- (3) 5/16-18 x 1" Bolt + 5/16-18 Nut (Hex Flange)
- (1) 3/4" Spacer Board
- (2) 9-1/2"W Back Boards
- (2) 7-1/2"W Seat Boards
- (3) Seat Brackets

UPHOLSTERED PANEL HARDWARE LIST

- (2) Flat Washers
- (2) Thumb Screws

STEP 1

Place brackets on the floor center-to-center using measurements below.

24"W Banquette: 18-1/2" (2 brackets)

30"W Banquette: 24-1/2" (2 brackets)

48"W Banquette: 42-1/2" (2 brackets)

60"W Banquette: 27-1/4" (3 brackets)

72"W Banquette: 33-1/4" (3 brackets)

STEP 2

See diagram to the right for spacing of the back and seat boards.

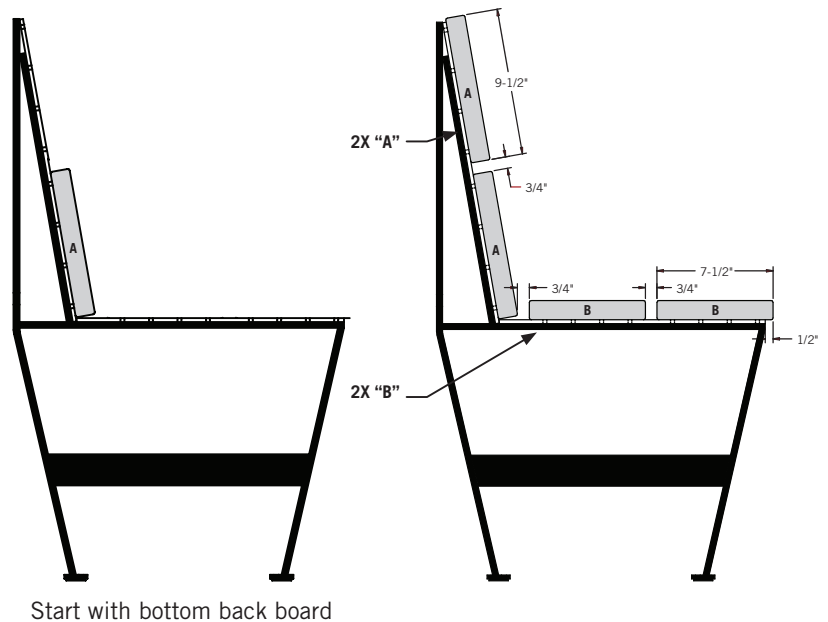

STEP 3

Place boards on the brackets, with the 9-1/2" boards on the back and the 7-1/2" boards on the seat, as shown in **Step 2**.

Secure the remaining boards on the brackets with screws using the 3/4" wide spacer to keep each board in the proper location while attaching them.

Once all boards are placed on the bracket, screw each board to the brackets using the holes in the metal bracket plates using the proper torque setting for your drill.

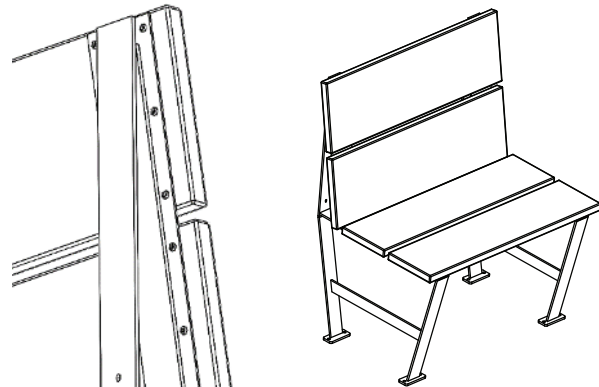

STEP 4

See optional instructions if cushions were ordered for the banquette or if banquette will be double-sided. If not, ensure the banquette is in the correct position and secure it to the floor using hardware suited to the floor substrate. Secure to the floor through the holes in the foot plate. Each foot plate needs at least one fastener.

Please note, Crow Works only provides hardware for the assembly of the banquette and not to fix the product to the floor. Please use an appropriate fastener for your application. The foot plate is 1/4" thick and has (2X) 3/8" holes for securing to the floor.

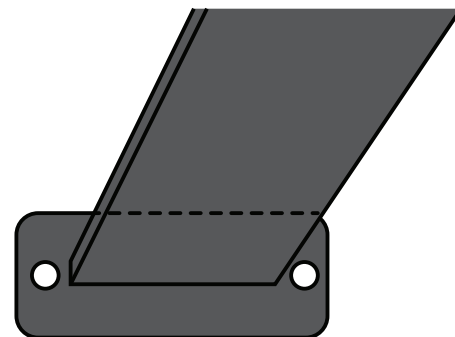

FOOT PLATE

FOR DOUBLE-SIDED BOOTH

Secure booths to each other using (2) hex flange bolts and nuts.

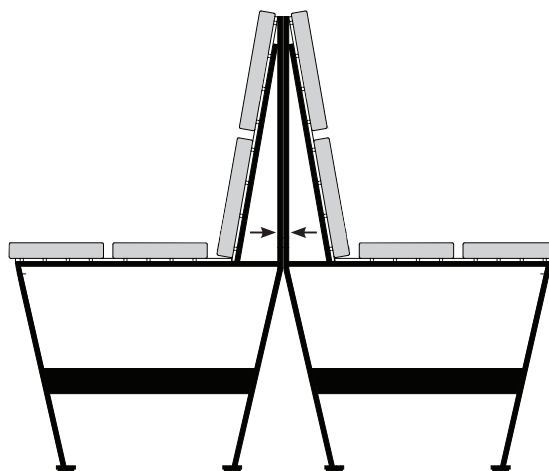

ADDING UPHOLSTERED PANELS

STEP A

Set upholstered panel wood spine into the slot between the two boards and center the cushion on the booth.

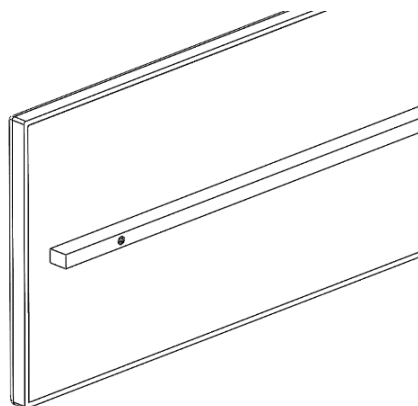

STEP B

To secure cushions, place a flat washer around the predrilled hole in the wood spine. Then, use a thumb screw to secure the washer and cushion into place. Repeat for all predrilled holes in all cushions.

